



US006023570A

United States Patent [19]  
Tang et al.

[11] Patent Number: 6,023,570  
[45] Date of Patent: Feb. 8, 2000

- [54] SEQUENTIAL AND SIMULTANEOUS MANUFACTURING PROGRAMMING OF MULTIPLE IN-SYSTEM PROGRAMMABLE SYSTEMS THROUGH A DATA NETWORK
- [75] Inventors: **Howard Y. M. Tang**, San Jose; **Cyrus Y. Tsui**, Los Altos; **Albert Chan**, Palo Alto, all of Calif.
- [73] Assignee: **Lattice Semiconductor Corp.**, Hillsboro, Oreg.
- [21] Appl. No.: **09/023,506**
- [22] Filed: **Feb. 13, 1998**
- [51] Int. Cl.<sup>7</sup> ..... **G06F 13/38**
- [52] U.S. Cl. .... **395/500.18**; 326/38; 326/39
- [58] Field of Search ..... 395/500, 500.18, 395/500.02; 326/38, 37

OTHER PUBLICATIONS

Brown et al, "Remote Service Methods for Cellular Communication Systems," 1995 IEEE 45th Vehicular Technology Conference, pp. 170-174.

S. Nisbet et al.: "The XC6200DS Development System" Field-Programmable Logic and Applications. 7th International Workshop, FPL '97. Proceedings, London, UK, Sep. 1-3, 1997, pp. 61-68, XP000783988 ISBN 3-540-63465-7, 1997, Berlin, Germany, Springer-Verlag, Germany.

M. A. Moran: Customers' Needs Drive Complex PLDs to In-System Programmability. WESCON/95 Conference, 'Microelectronics Communications Technology Producing Quality Products Mobile and Portable Power Emerging Technologies.' Nov. 1995, pp. 213-217.

*Primary Examiner*—Kevin J. Teska  
*Assistant Examiner*—Samuel Broda  
*Attorney, Agent, or Firm*—Skjerven, Morrill, MacPherson, Franklin & Friel LLP

[56] References Cited

U.S. PATENT DOCUMENTS

4,849,928	7/1989	Hauck	364/900
5,237,218	8/1993	Josephson et al.	307/465
5,309,351	5/1994	McCain et al.	364/132
5,457,408	10/1995	Leung	326/38
5,543,730	8/1996	Cliff et al.	326/38
5,581,779	12/1996	Hall et al.	395/800.43
5,635,855	6/1997	Tang	326/38
5,734,868	3/1998	Curd et al.	395/500
5,751,163	5/1998	Tang et al.	326/38
5,833,469	11/1998	Ito et al.	434/307 A

FOREIGN PATENT DOCUMENTS

0 806 737	11/1997	European Pat. Off.	G06F 17/50
94 08399	4/1994	WIPO	H03K 19/177

[57] ABSTRACT

An in-system programmable (ISP) system, having a plurality of ISP devices, can be programmed by remote access from a host controller. The remote access can be accomplished over a wired data network, a wireless data network such as an infra-red data network and a radio wave data network, or a hybrid network including both a wired data network portion and a wireless data network portion. An access interface connects the host controller to an ISP programmer over the wired or wireless communication link. The ISP programmer programs the ISP system in accordance with ISP programming conventions. The ISP programmer can be provided by an integrated circuit having a microprocessor core.

69 Claims, 9 Drawing Sheets

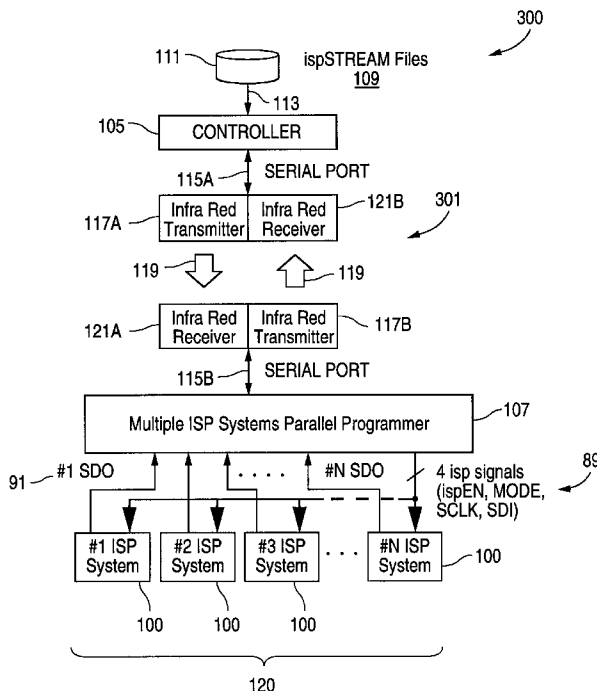

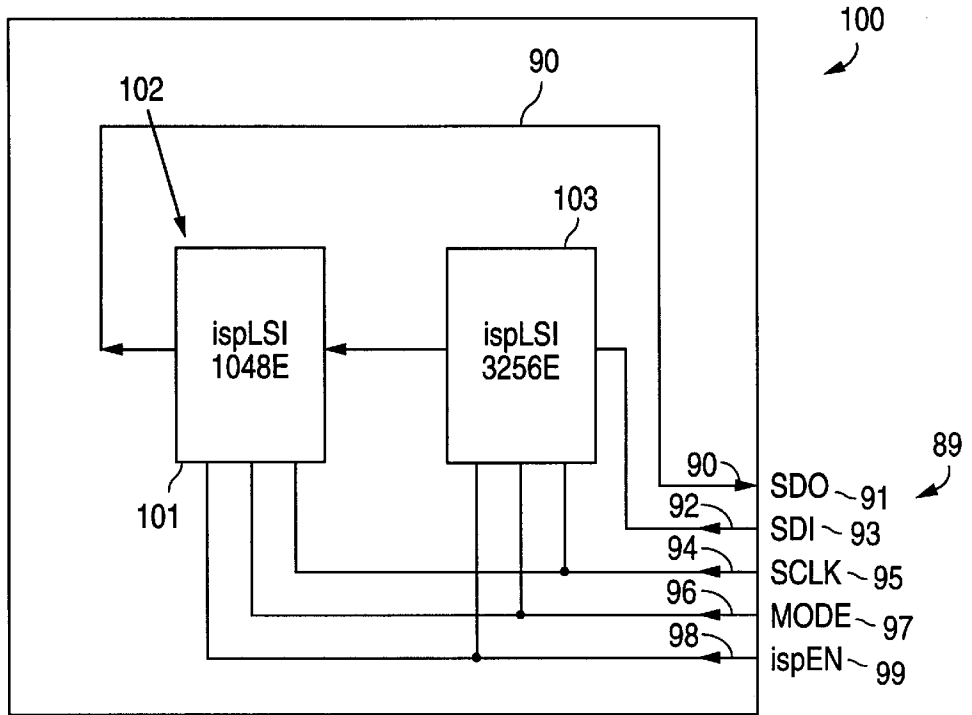

FIG. 1

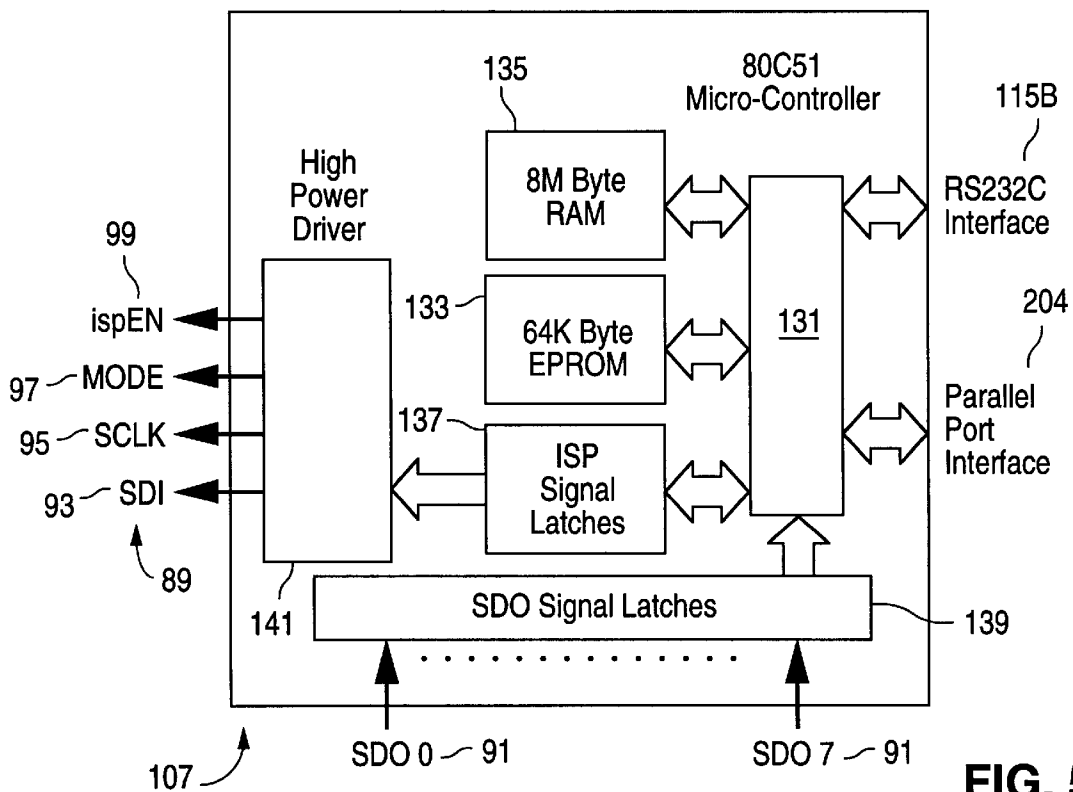

FIG. 5

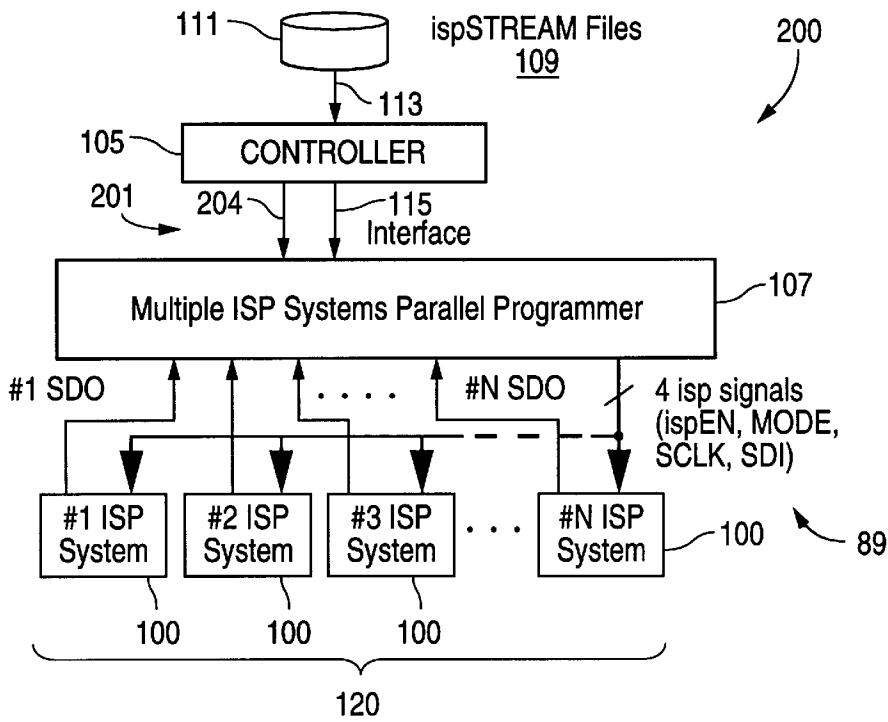

FIG. 2

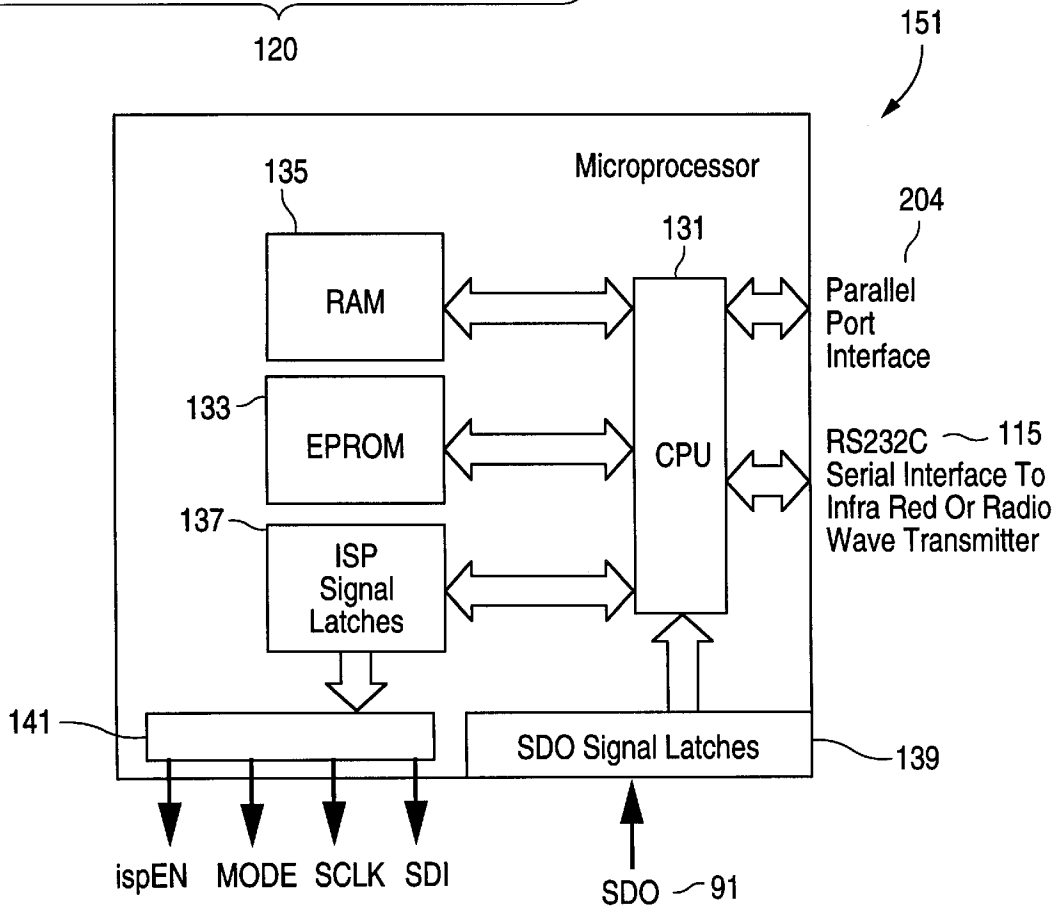

FIG. 9

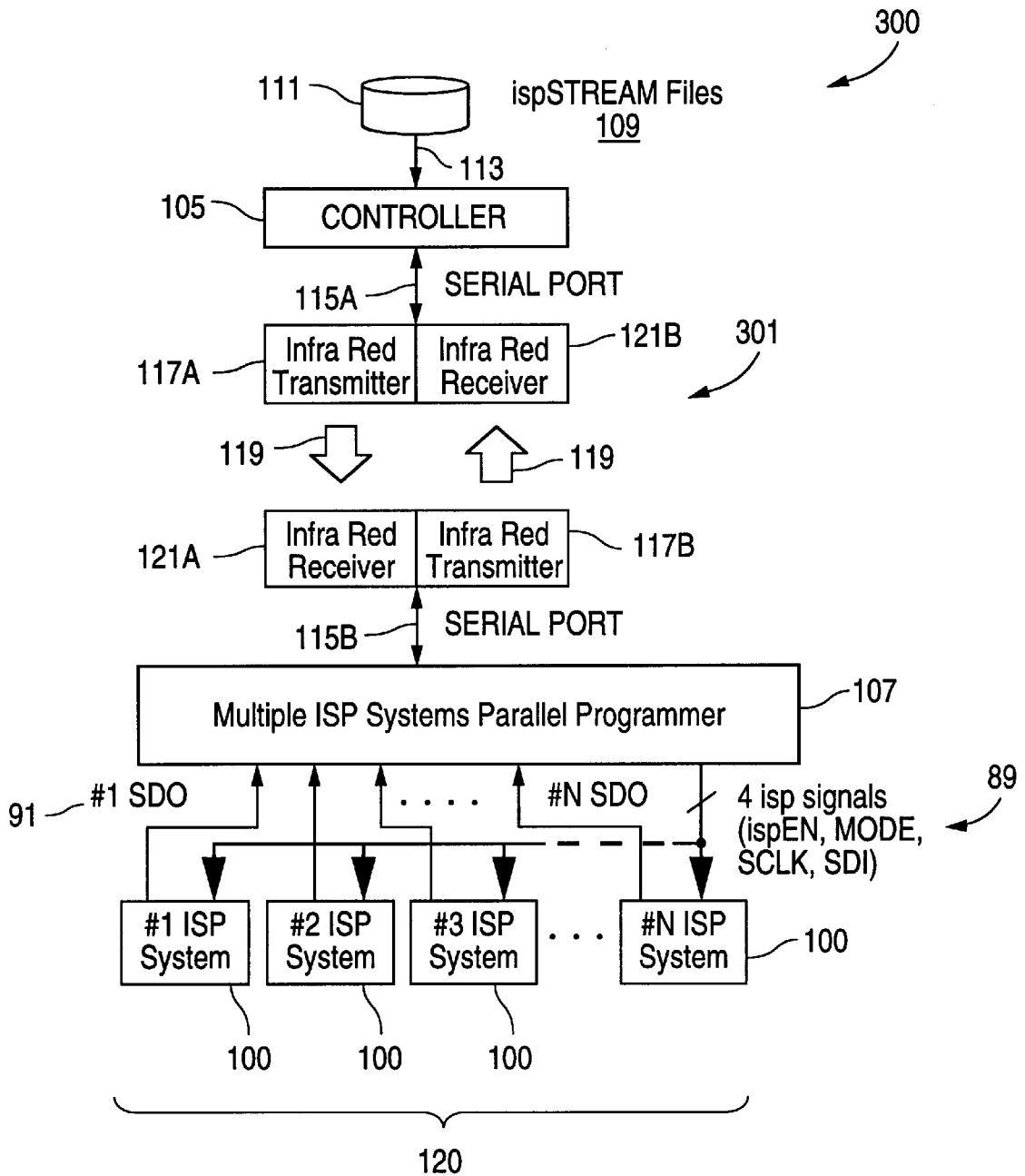

FIG. 3

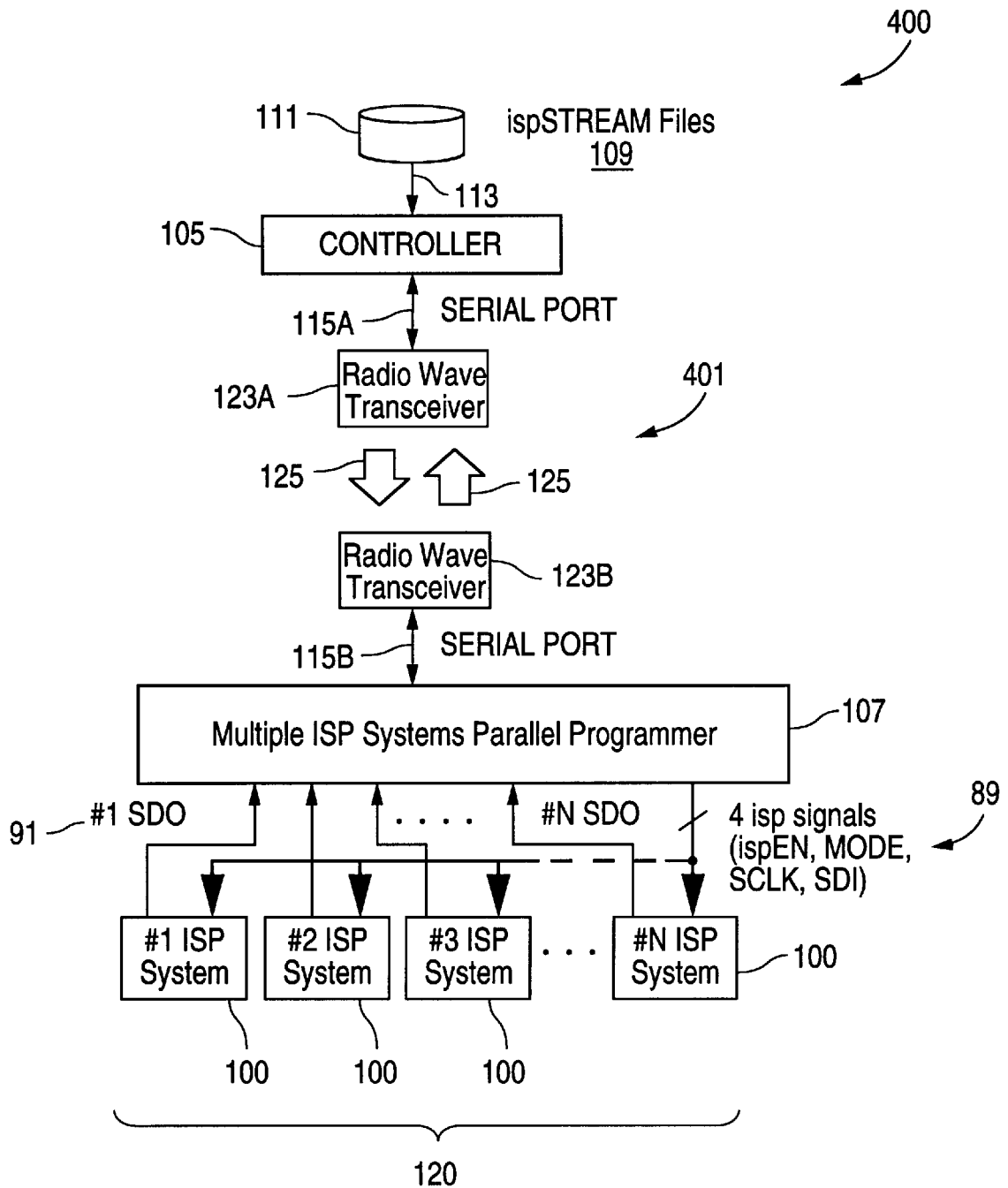

FIG. 4

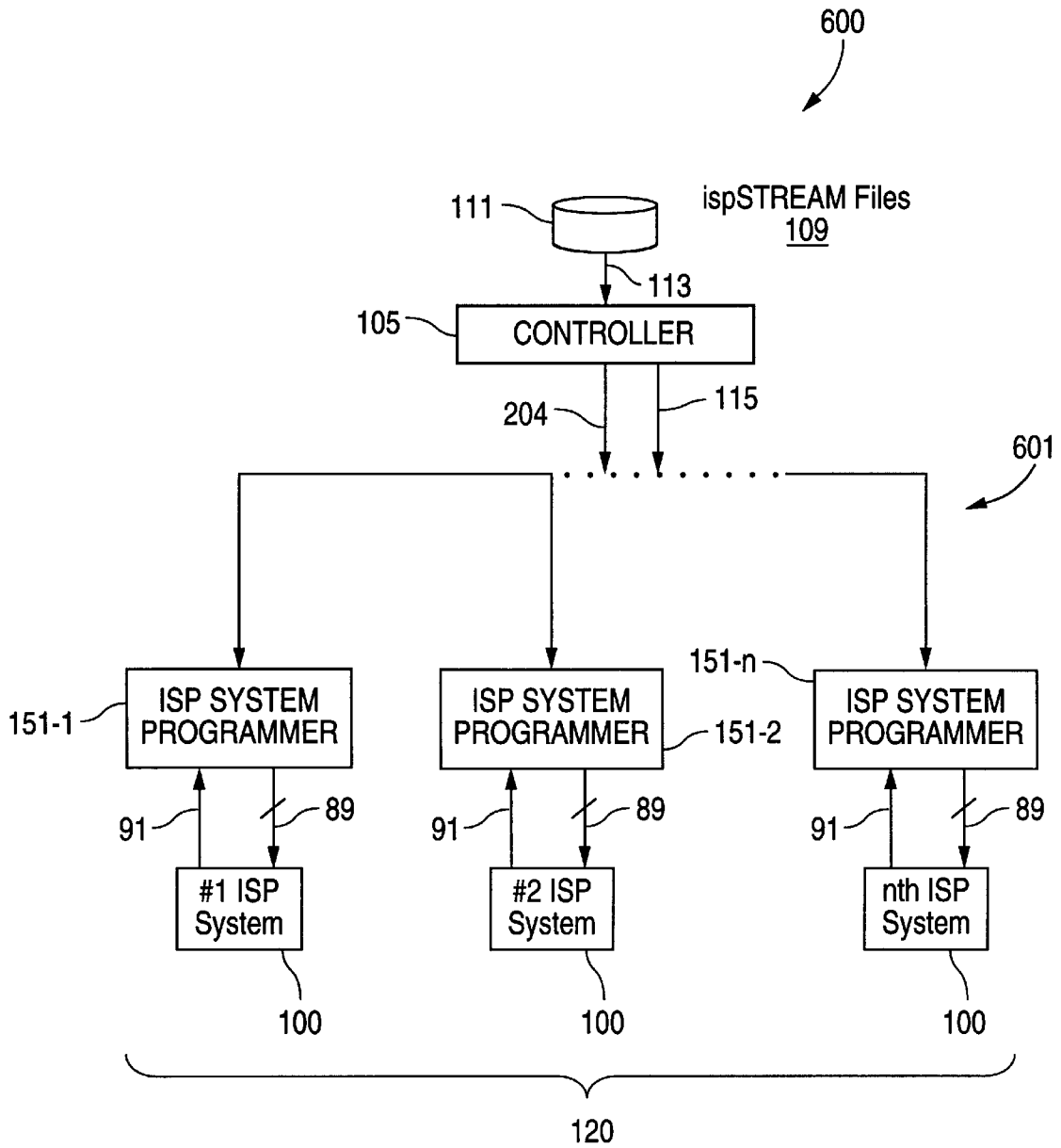

FIG. 6

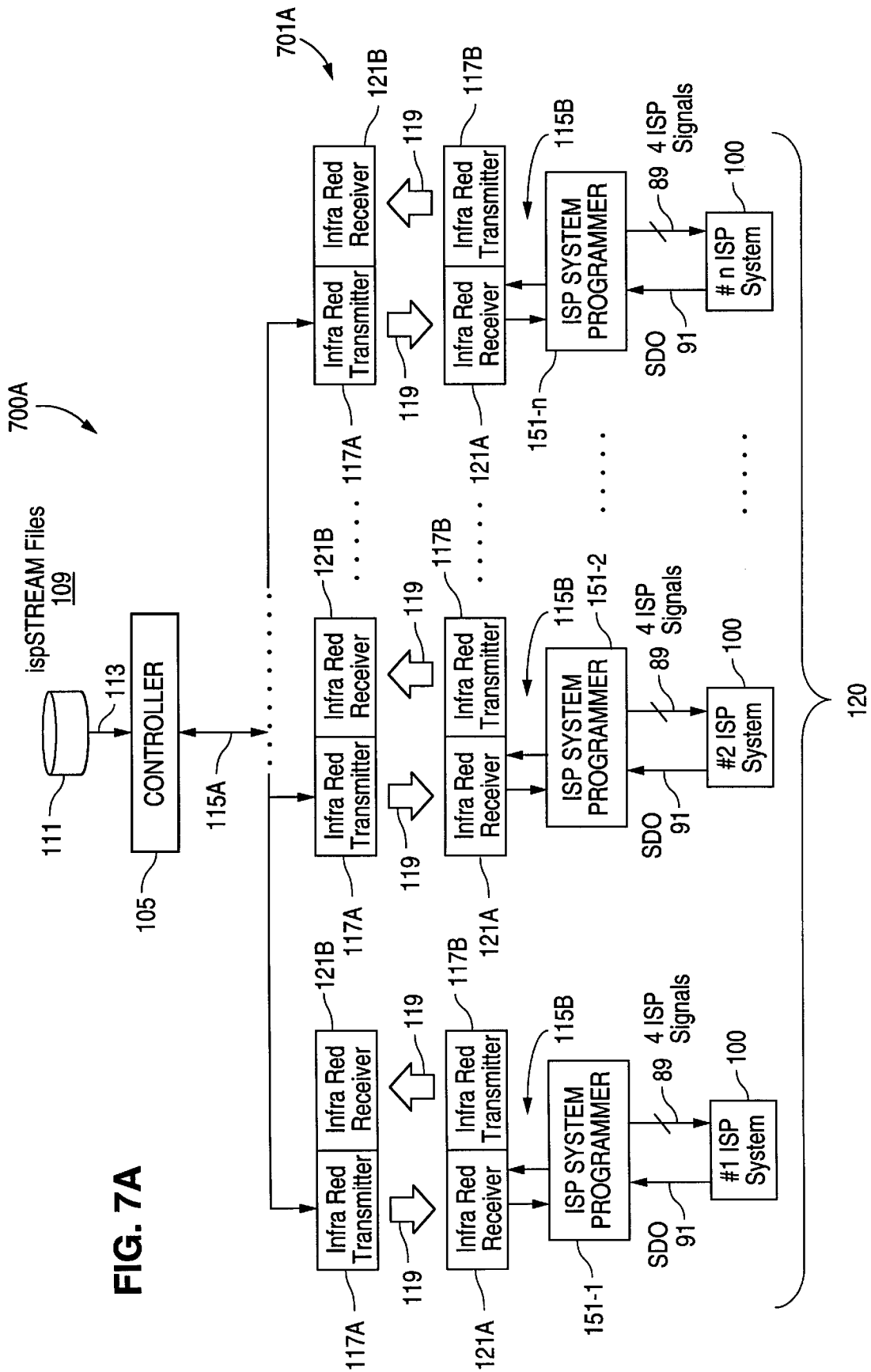

FIG. 7A

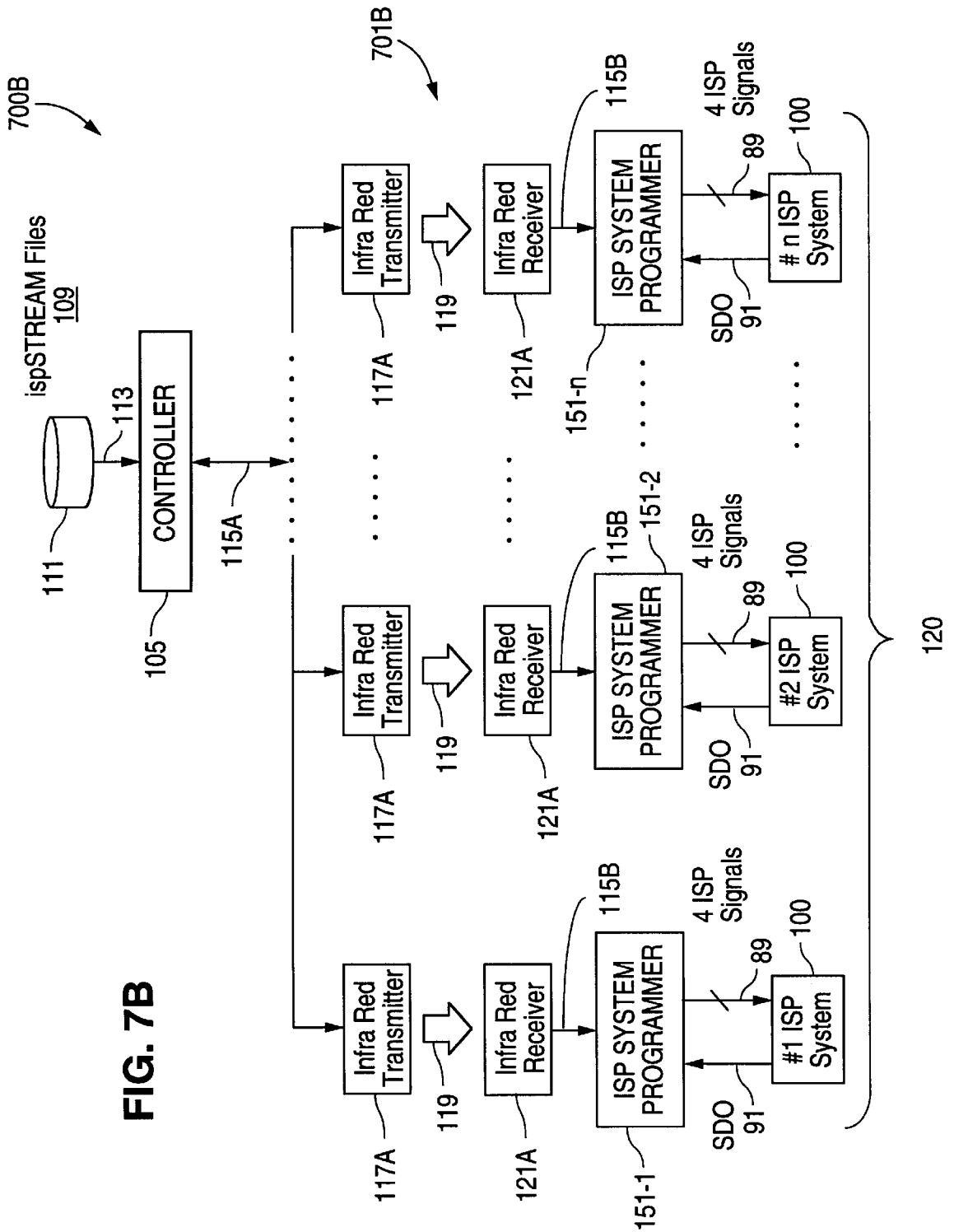

FIG. 7B



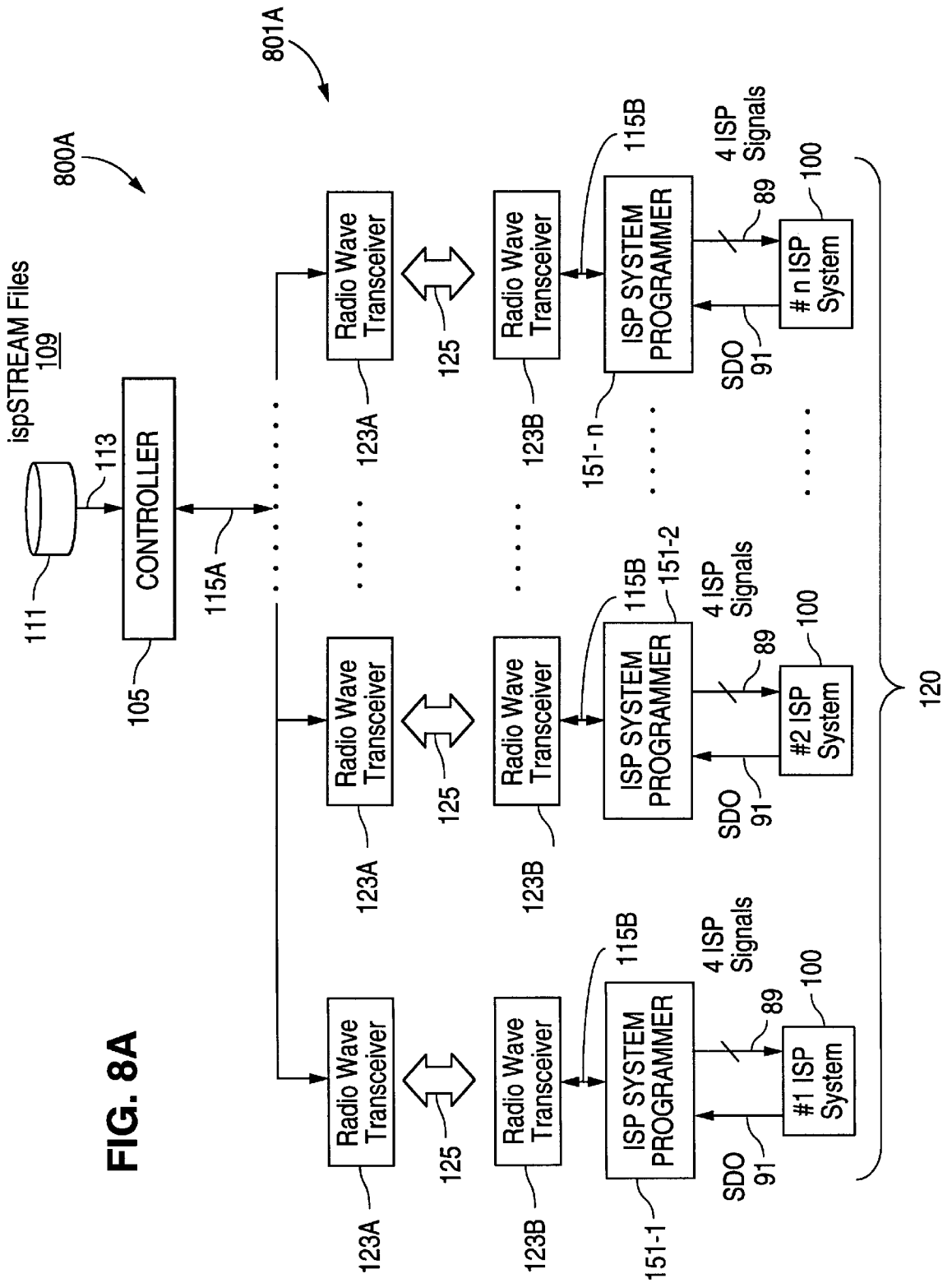

FIG. 8A

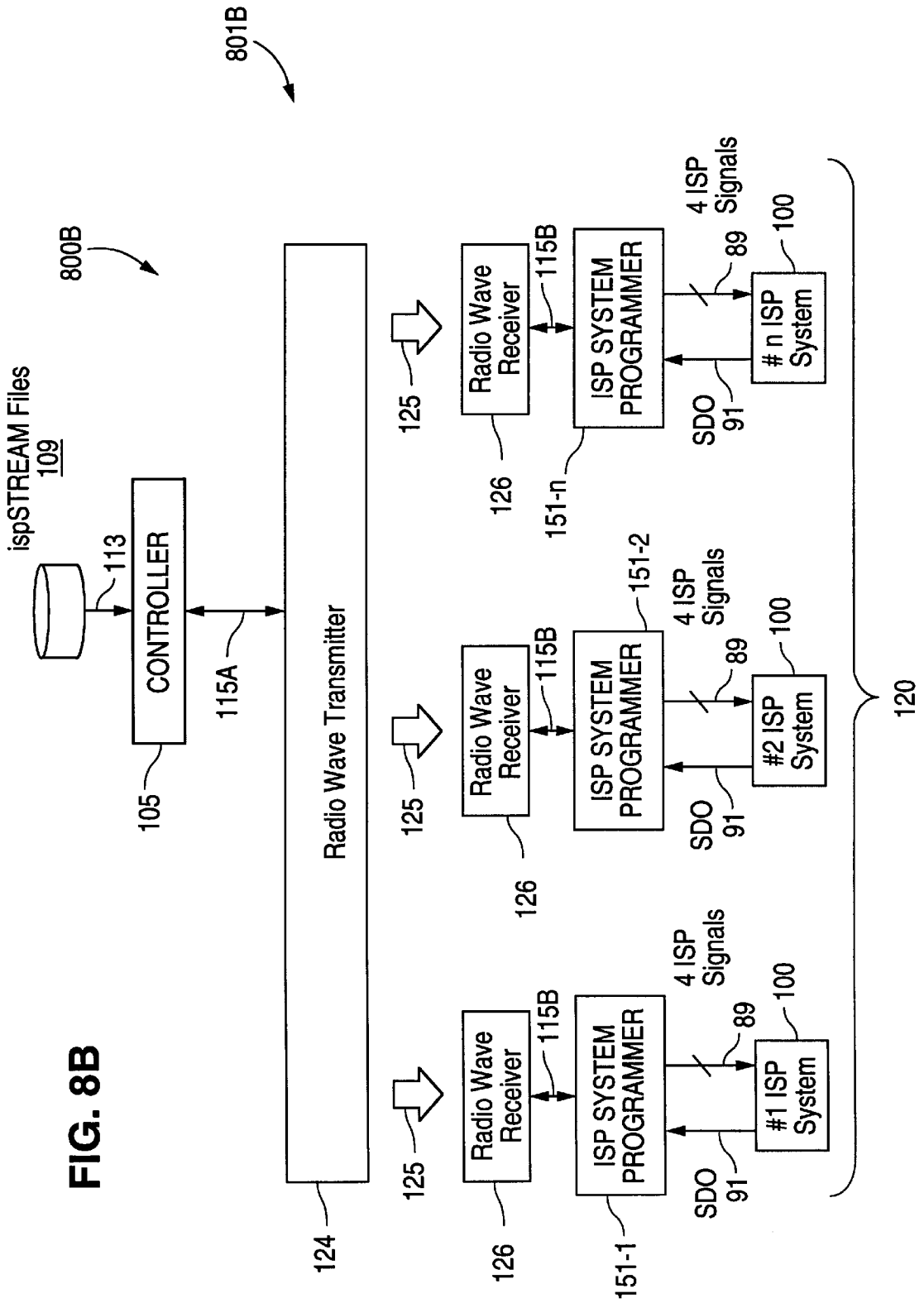

FIG. 8B

# SEQUENTIAL AND SIMULTANEOUS MANUFACTURING PROGRAMMING OF MULTIPLE IN-SYSTEM PROGRAMMABLE SYSTEMS THROUGH A DATA NETWORK

## BACKGROUND OF THE INVENTION

### 1. Field of the Invention

This invention relates to programmable integrated circuits. More specifically, the present invention relates to techniques for programming, sequentially or simultaneously, multiple printed circuit boards which include programmable integrated circuits.

### 2. Description of the Related Art

Programmable devices that can be programmed and reprogrammed without being removed from their application environment are very valuable in many applications. One type of such device is the "In-System Programmable Logical Device" or "ISP PLD," available from Lattice Semiconductor Corporation. The term "manufacturing programming" refers to the programming of blank "ISP PLD" devices which are already mounted on the printed circuit boards. Such programming is typically achieved by transferring into the "ISP PLD" a bit pattern, which is typically provided to the programmer in an industry standard data format called the JEDEC file format. A method for converting a file in the JEDEC file format to an ispSTREAM file format, which is a file format widely adopted for use with "ISP PLD" devices, is disclosed in U.S. Pat. No. 5,635,855, entitled "Method for Simultaneous Programming of In-System Programmable Integrated Circuits," to Tang et al., filed on Jul. 21, 1995 and issued on Jun. 3, 1997.

A reprogrammable system is reprogrammed by a host programming device over a hard-wired connection. It is desirable to allow such a programmable system to be reprogrammed over wired or wireless links established at the time of reprogramming, so as to allow reprogramming by a remote programmer (e.g., a portable programming device or a programming device), regardless of where the programmer is located.

## SUMMARY OF THE INVENTION

The present invention provides a system for programming multiple programmable integrated circuits. In one embodiment, such a system includes: a) an in-system programmable (ISP) system having multiple ISP devices (e.g., in-system programmable logical devices or "ISP PLDs," available from Lattice Semiconductor Corporation); b) a programmer communicating with the ISP system for programming the ISP devices; c) a controller (e.g., a PC or a Workstation) which transmits control data and programming data (e.g., an ispSTREAM file) to the programmer; and d) an access interface (e.g., a serial or parallel port interface) in the programmer which connects the controller to the programmer over a communication link (e.g., a communication link in a hardwire data network, an infra-red data network, or a radio wave data network).

In accordance with one aspect of the present invention, at the beginning of the programming, programming data is transferred to a controller, such as a PC or a Workstation, which stores the data in a mass storage device, such as a hard disk. The controller then establishes communication with a Multiple Systems Parallel Programmer (Parallel Programmer) over a communication link. The communication link connects the controller to the access interface of the Parallel Programmer. The communication link can be a

wired or a wireless data network, such as a radio wave or an infra-red signal.

In accordance with another aspect of the present invention, the Parallel Programmer includes a central processing unit (CPU) and the access interface implemented by either a serial or a parallel port interface. The Parallel Programmer can additionally include a writeable control store, e.g., one that is implemented by an erasable programmable read-only memory ("EPROM"), accessible by the central processing unit. The writeable control store includes the operation program of the Parallel Programmer. Programming data received from the controller through the access interface are typically stored in a random access memory ("RAM") of the Parallel Programmer. From the RAM, programming data is typically provided to a clocked memory element (e.g., a set of latches) to drive ISP programming signals. Multiple ISP systems can be programmed in a parallel.

Each ISP device is programmed under the control of a programming clock signal and a mode signal. The ISP devices receive control and programming data from a serial input signal and provide data output, including status, control and programming data, through a serial output signal.

Alternatively, multiple ISP System Programmers ("Programmers") can be used in place of a single Parallel Programmer. Typically, each Programmer is equipped similar to a Parallel Programmer except that, in this embodiment, a different Programmer is connected to each ISP system, so as to allow the Programmers to program their respective ISP systems simultaneously. In contrast, a Parallel Programmer programs its ISP systems sequentially.

## BRIEF DESCRIPTION OF THE DRAWINGS

FIG. 1 illustrates an in-system programmable (ISP) system **100**; ISP system **100** includes ISP devices **102** represented by ispLSI devices **101** and **103**.

FIG. 2 illustrates a first configuration **200** of a first embodiment of the present invention, utilizing a Multiple ISP Systems Parallel Programmer (Parallel Programmer) **107**, which is remotely accessible by a controller **105** over a wired data network **201**.

FIG. 3 illustrates a second configuration **300** of the first embodiment of the present invention, utilizing Parallel Programmer **107**, which is remotely accessible by controller **105** over a wireless infra-red data network **301**.

FIG. 4 illustrates a third configuration **400** of the first embodiment of the present invention, utilizing Parallel Programmer **107**, which is remotely accessible by controller **105** over a wireless radio wave data network **401**.

FIG. 5 illustrates components of Parallel Programmer **107**, suitable for programming and reprogramming ISP systems **100** of FIGS. 1-4.

FIG. 6 illustrates a first configuration **600** of a second embodiment of the present invention, utilizing multiple ISP System Programmers **151**, which are remotely accessed by controller **105** over a wired data network **601**.

FIG. 7A illustrates a second configuration **700A** of the second embodiment of the present invention, utilizing multiple ISP System Programmers **151**, which are remotely accessed by controller **105** over a wireless infra-red data network **701A**.

FIG. 7B illustrates a third configuration **700B** of the second embodiment of the present invention, utilizing multiple ISP System Programmers **151**, which are remotely accessed by controller **105** over a one-way wireless infra-red data network **701B**.

FIG. 8A illustrates a fourth configuration 800A of the second embodiment of the present invention, utilizing multiple ISP System Programmers 151, which are remotely accessed by controller 105 over a wireless radio wave data network 801A.

FIG. 8B illustrates a fifth configuration 800B of the second embodiment of the present invention, utilizing multiple ISP System Programmers 151, which are remotely accessed by controller 105 over a one-way wireless radio wave data network 801B.

FIG. 9 illustrates components of ISP System Programmers 151, suitable for programming and reprogramming ISP systems 100 of FIGS. 1, 6, 7A, 7B, 8A and 8B.

#### DETAILED DESCRIPTION OF THE PREFERRED EMBODIMENTS

The present invention is specifically illustrated in this detailed description using configurations for remotely accessing and programming an in-system programmable (ISP) system over a wired or wireless data network. In this description, to simplify discussion, like elements in the drawings are provided like reference numerals.

FIG. 1 illustrates an ISP system 100 including ISP devices 102 ("ISP PLDs"), represented by ispLSIs 101 and 103. ISP devices 102 are programmed using four (4) ISP input signals 89. Input signals 89 consist of a serial data input signal 93 (SDI), a clock signal 95 (SCLK), a control signal 97 (MODE), and an ISP mode enable signal 99 (ispEN). The programmed data can be read out through serial data output signal 91 (SDO) using a "verify" command implemented in an ISP state machine of the ISP PLD. Signals 95, 97, and 99, provided respectively on terminals 94, 96, and 98, are applied in parallel to each of ispLSIs 101 and 103 to control their programming. In addition, as shown in FIG. 1, signal 93 (i.e., serial data input signal SDI) is transmitted via terminal 92 through a daisy chain of the SDI and SDO terminals of ispLSI 101 and 103. The functions of input signals 89 are: (a) SCLK signal 95 synchronizes shifting of programming data 109; (b) MODE signal 97 indicates whether control data or programming data 109 is shifting into or out of ISP devices 102; and (c) ispEN signal 99 causes a state machine within each of ispLSIs 101 and 103 to go into a programming mode.

Manufacturing programming of multiple ISP systems under the present invention is illustrated in the configurations shown in FIGS. 2-4 and 6-8B. Referring to FIG. 2, programming of the numerous ISP systems 120 of configuration 200, each labeled 100, is initiated when programming data 109 are transferred from a storage element 111 to a controller 105 by a floppy disk or via a communication link, as indicated by arrow 113 (see also FIGS. 3, 4 and 6-8B). Programming data 109, for example, can be provided by an ispSTREAM file, which is a file format widely adopted for use with ISP PLDs and its definition is available from Lattice Semiconductor Corporation. In an ispSTREAM file, programming commands and programming data 109 for the ISP PLDs are compiled in a binary format. Controller 105, which can be implemented by a personal computer (PC) or a workstation, stores programming data 109 in a mass storage device, such as a hard disk. As shown in FIG. 2, controller 105 is coupled to a Multiple ISP Systems Parallel Programmer (Parallel Programmer) 107 through a communication link 201. Communication link 201 represents a wired data network coupling controller 105 coupled to a standard parallel port 204 or a serial port 115 of the PC or the workstation.

In alternative configurations illustrated by configurations 300 and 400 of FIGS. 3 and 4, communication between controller 105 and an access interface (e.g., serial port interface 115B) of Parallel Programmer 107 can be provided by an infra-red communication link 301 (FIG. 3), or a radio wave communication link 401 (FIG. 4). Referring to FIG. 3, controller 105 sends commands or programming data 109 in 8-bit bytes to a serial port interface 115A. The commands and programming data are transmitted by an infra-red transmitter 117A as sequence pulses 119. A receiver 121A at the access interface (i.e., serial port interface 115B) of Parallel Programmer 107 receives pulses 119 and reconstitutes pulses 119 as commands and programming data to Parallel Programmer 107. As communication link 301 is bi-directional, data is transferred from Parallel Programmer 107 to controller 105 by infra-red communication link 301 in substantially the same manner as described above but in the reverse direction through transmitter 117B and receiver 121B. Infra-red wireless communication link 301 allows Parallel Programmer 107 to be physically and electrically isolated from controller 105, thus providing flexibility in implementation. Electrical isolation reduces electrical noises coupled into Parallel Programmer 107 from controller 105, resulting in a more reliable and higher quality ISP programming.

Similarly, referring to configuration 400 of FIG. 4, wireless radio wave communication link 401 is provided in place of infra-red communication link 301 of FIG. 3. In configuration 400, data is sent between controller 105 and Parallel Programmer 107 by transceivers 123A and 123B at the serial ports 115A and 115B respectively. Thus, as in configuration 300, configuration 400 provides a ISP programming system in which controller 105 is electrically isolated from Parallel Programmer 107, thus ensuring highly reliable ISP programming operations.

Those skilled in the art would appreciate from configurations 200, 300 and 400 that many variations and modifications of communication links 201, 301 and 401 can be practiced within the scope of the present invention. For example, communication links between controller 105 and Parallel Programmer 107 can be implemented in a network including both wired and wireless components interconnected by "gateways."

Controller 105 runs a program which controls the operations of the Parallel Programmer 107. An implementation of Parallel Programmer 107 is illustrated in FIG. 5. As shown in FIG. 5, Parallel Programmer 107 includes a central processing unit (CPU) 131 (e.g., a 80C51 micro-controller) which executes from a writeable control store implemented by a non-volatile storage element 133 (e.g., a 64K Byte EPROM). Programming data 109, when received from controller 105 via serial port 115B (e.g., RS232C Interface) or parallel port 204 interface, are stored in a random access memory 135 (e.g. 8M Byte RAM). During programming, programming data 109 are read from RAM 135 and provided to a clocked memory element 137 (e.g., a group of signal latches) at a much higher clock rate than the baud rate of serial ports 115B or parallel port 204 to ensure high speed programming operations. Clocked memory element 137 holds values of input signals 89 and provides them to high power drivers 141. This ensures that input signals 89 are provided to each of ISP systems 120 such that the setup time and the hold time requirements on SDI signal 93 and MODE signal 97 relative to SCLK signal 95 are met. A clocked memory element 139 (e.g., a group of latches) receives and holds output data from the SDO signal 91 from ISP systems 120. The operations of Parallel Programmer 107 is discussed in further detail below.

The operation of the controller **105** is summarized in steps 1.1 to 1.10 as follows:

Step 1.1: Controller **105** establishes communication with Parallel Programmer **107**. In configuration **200** (FIG. **2**), wired communication link **201** couples parallel port **204** or serial port **115** of controller **105** (e.g., a PC or a workstation) to Parallel Programmer **107**. In wireless configurations **300** and **400** (FIGS. **3** and **4**), infra-red and radio wave communication links **301** and **401** couple serial port **115A** to Parallel Programmer **107**.

Step 1.2: CPU **131** of Parallel Programmer **107** acknowledges to controller **105** the communication link established at its access interface. CPU **131** executes from control store **133** an operational program which readies Parallel Programmer **107** for receiving transmission of programming data **109**.

Step 1.3: Controller **105** sends commands to Parallel Programmer **107** and monitors the response from Parallel Programmer **107**. The following commands are sent by controller **105**:

- i) Connect: This command initiates a connection between Parallel Programmer **107** and controller **105**;
- ii) Load programming data: This command transfers specified programming data **109** to Parallel Programmer **107**;
- iii) Program and Verify: This command starts programming operations in Parallel Programmer **107**, including verifying programming echoed from ISP systems **120**, thus verifying correct programming of ISP systems **120**;
- iv) Verify: This command initiates in Parallel Programmer **107** “verify” operations in every one of ISP systems **120**; and
- v) Hardware Check: This command initiates a self-check in Parallel Programmer **107**.

Step 1.4: Controller **105** retrieves programming data **109** from mass storage device **111** (e.g., disk storage).

Step 1.5: Controller **105** sends the Load programming data command and transmits programming data **109** to Parallel Programmer **107**.

Step 1.6: CPU **131** of Parallel Programmer **107** stores programming data **109** into RAM **135**. CPU **131** then sends an acknowledgment signal to controller **105** to indicate readiness for the next command.

Step 1.7: Controller **105** sends the Program and Verify command to start the programming and verification process.

Step 1.8: CPU **131** executes a control program which sends ISP program and verify commands to each of ISP systems **120**.

Step 1.9: Controller **105** sends the Verify command and CPU **131** returns to controller **105** the result of the VERIFY operation in each of ISP systems **120**.

Step 1.10: Controller **105** reports (e.g., by displaying on a monitor) successful or unsuccessful completion of programming for each of ISP systems **120**.

The operation of Parallel Programmer **107** is summarized by steps 2.1–2.16 as follows:

Step 2.1: Parallel Programmer **107** waits in a standby mode until commands arrive from controller **105**.

Step 2.2: When Parallel Programmer **107** receives a Load programming data command from controller **105**, Parallel Programmer **107** reads programming data **109**, byte by byte, from serial port **115B** or parallel port **204** and stores programming data **109** received into the RAM **135**.

Step 2.3: Having received programming data **109**, Parallel Programmer **107** signals controller **105** that step 2.2 is completed.

Step 2.4: Parallel Programmer **107** then calculates a checksum for programming data **109** and compares the checksum thus calculated with the checksum appended to the end of programming data **109** to verify that the transmission was successful and that no data corruption has occurred in the transmission process.

Step 2.5: Parallel Programmer **107** reports the result of the transmission to controller **105**.

Step 2.6: Parallel Programmer **107** waits for the next command from controller **105**.

Step 2.7: Parallel Programmer **107** receives the Program and Verify command, and transfers programming data **109**, byte by byte, from the RAM **135** into clocked memory element **137**.

Step 2.8: Clocked memory element **137** drives ispEN signal **99** low, thereby setting all of ISP systems **120** into programming mode in parallel.

Step 2.9: Clocked memory element **137** drives SDI signal **93** and SCLK signal **95** to shift ISP instructions and programming data **109** into ISP devices **102** of ISP systems **120** in parallel.

Step 2.10: Clocked memory element **137** drives MODE signal **97** and SCLK signal **95** to step ISP devices **102** in ISP systems **120** to complete the ISP programming cycles in parallel.

Step 2.11: Clocked memory element **137** drives SCLK signal **95** to shift data out from terminal **90** (SDO signal **91**) in each of ISP systems **120** in parallel.

Step 2.12: Clocked memory element **139** latches in parallel SDO signals **91** from all ISP systems **120**.

Step 2.13: The data in clocked memory element **139** are read by CPU **131** and verified. Any failure in any of ISP systems **120** is recorded by Parallel Programmer **107**.

Step 2.14: Steps **2.7–2.13** are repeated until all of ISP systems **120** are programmed.

Step 2.15: Parallel Programmer **107** reports any failure recorded for each of ISP systems **120** to controller **105**.

Step 2.16: Parallel Programmer **107** returns to step 2.1. The following is an exemplary sequence of events representative of the programming of an ISP device (e.g. any of ISP devices **102**) using ISP signals **89**:

Step 3.1: Setting the ISP device to SHIFT state.

Step 3.2: Sending an ERASE command to the ISP device.

Step 3.3: Setting ISP device to EXECUTE state.

Step 3.4: Holding ISP signals **89** for 200 milliseconds, thereby erasing any pre-existing programming in the ISP device.

Step 3.5: Setting the ISP device to SHIFT state.

Step 3.6: Sending an ADDRESS SHIFT command to the ISP device.

Step 3.7: Setting the ISP device to EXECUTE state.

Step 3.8: Sending an address to the ISP device.

Step 3.9: Setting the ISP device to SHIFT state.

Step 3.10: Sending a DATA SHIFT command to the ISP device.

Step 3.11: Setting the ISP device to EXECUTE state.

Step 3.12: Sending programming data **109** to the ISP device.

Step 3.13: Setting the ISP device to SHIFT state.

- Step 3.14: Sending a PROGRAM command to the ISP device.
- Step 3.15: Setting the ISP device to EXECUTE state.
- Step 3.16: Holding ISP signals **89** for 40 milliseconds, thereby programming a new pattern (i.e., the pattern represented by programming data **109**) into the ISP device.
- Step 3.17: Setting the ISP device to SHIFT state.
- Step 3.18: Sending a VERIFY command to the ISP device.
- Step 3.19: Setting the ISP device to EXECUTE state.
- Step 3.20: Holding ISP signals **89** for 30 milliseconds, thereby verifying the new pattern in the ISP device.
- Step 3.21: Setting the ISP device to the SHIFT state.
- Step 3.22: Sending a DATA SHIFT command to the ISP device.
- Step 3.23: Setting the ISP device to EXECUTE state.
- Step 3.24: Shifting programming data **109** out as the SDO signal, so that a checksum can be computed to verify whether the ISP device **102** is properly programmed.

In a second embodiment, illustrated by configurations **600**, **700A**, **700B**, **800A** and **800B** of FIGS. **6**, **7A**, **7B**, **8A** and **8B**, respectively, each ISP system **100** in ISP systems **120** can be programmed using a plurality of ISP System Programmers (Programmers) **151-1**, **151-2**, . . . , **151-n**. In contrast to the first embodiment described above, where a single Parallel Programmer **107** is coupled to ISP systems **120**, in second embodiments **600**, **700**, and **800**, a Programmer (e.g. Programmer **151-1**) is coupled to a single ISP system **100** in ISP systems **120**.

As in the first embodiment described above, programming of ISP systems **120** is initiated when controller **105** receives programming data **109** from storage element **111**. Controller **105** is connected to each of Programmers **151-1**, **151-2**, . . . , and **151-n** over a communication link. Each communication link between controller **105** and Programmers **151-1**, **151-2**, . . . , and **151-n** can be provided by a wired or wireless data network. In a wired data network, a hardwired connection through standard parallel port **204** or serial port **115** of controller **105** is utilized, generally illustrated in FIG. **6** as a wired communication link **601**. Wireless communication links are illustrated in FIGS. **7A** and **7B** by infra-red communication links **701A** and **701B**, respectively, and in FIGS. **8A** and **8B** by radio wave communication links **801A** and **801B**, respectively.

Referring to FIG. **7A**, controller **105** sends commands and programming data **109** in 8-bit bytes to serial port interface **115A**. Serial port interface **115A** is connected to an array of infra-red transmitters **117A**. Transmitters **117A** convert and serialize the ISP commands or programming data **109** into light pulses **119**. Light pulses **119** transmitted from each of transmitters **117A** are detected and reconstituted by receivers **121A**. Commands or programming data **109** are received by each of Programmers **151-1**, **151-2**, . . . , and **151-n** via serial port **115B** through a receiver **121A** of associated Programmer **151-1**, **151-2**, . . . , and **151-n**. Data from each of Programmers **151-1**, **151-2**, . . . , and **151-n** are sent to controller **105** by infra-red transmitter **117B** and receiver **121B** over infra-red communication link **701A**, in the reversed direction.

Alternatively, as illustrated by configuration **700B** of FIG. **7B**, a one-way communication link can be provided between controller **105** and each of Programmers **151-1**, **151-2**, . . . , **151-n**. In configuration **700B**, Programmers **151-1**, **151-2**, . . . , **151-n** can be equipped with a device, such as a light

signal (not shown in FIG. **7B**) to indicated whether the programming is successful.

Referring to FIG. **8A**, wireless radio wave communication link **801A** is configured in the same manner as communication link **701A** of FIG. **7A**, except that radio waves, rather than infra-red radiation, are used. Similarly, configuration **800B** of FIG. **8B** illustrates one-way radio wave communication link **801B** between controller **105** and each of Programmers **151-1**, **151-2**, . . . , and **151-n**, operating in substantially the same manner as configuration **700B**.

FIG. **9** shows an implementation of a Programmer **151** (e.g., any one of Programmers **151-1**, **151-2**, . . . , and **151-n**), which includes substantially the same components as Parallel Programmer **107** of FIG. **5**, i.e., CPU **131**, non-volatile storage element **133**, RAM **135**, clocked memory elements **137** and **139**, and driver **141**. Of course, since Programmer **151** is connected to a single ISP system, clocked element **139**, which receives an output signal from an ISP device, can be 1-bit wide.

The operations of controller **105** for each of configurations **600**, **700A**, **700B**, **800A** and **800B** are summarized as follows:

Step 5.1: Controller **105** establishes a communication link with each of Programmers **151-1**, **151-2**, . . . , and **151-n**.

Step 5.2a: Controller **105** sends commands to all of Programmers **151-1**, **151-2**, . . . , and **151-n**. These commands include:

- i) Connect: This command searches and connects the recipient Programmer (e.g., Programmer **151-1**);
- ii) Load programming data: This command transfers programming data **109** to the recipient Programmer;
- iii) Program and Verify: This command starts programming operation in the recipient Programmer, including verifying programming echoed from ISP system **100** associated with the recipient Programmer;
- iv) Verify: This command starts verification of ISP system **100** associated with the recipient Programmer; and
- iv) Hardware Check: This command starts a self-check in ISP system **100** associated with the recipient Programmer.

Step 5.2b: Controller **105** monitors the response from each of Programmers **151-1**, **151-2**, . . . , and **151-n** in configurations in which the communication link is two-way.

Step 5.3: CPU **131** of each of Programmers **151-1**, **151-2**, . . . , and **151-n** acknowledges establishment of a communication link with controller **105**, indicating readiness to receive command or data.

Step 5.4: Controller **105** retrieves programming data **109** from storage element **111** (e.g., disk storage).

Step 5.5: Controller **105** sends the Load programming data command and transmits programming data **109** to each of Programmers **151-1**, **151-2**, . . . , and **151-n** simultaneously.

Step 5.6a: CPU **131** of each of Programmers **151-1**, **151-2**, . . . , and **151-n** stores programming data **109** into its associated RAM **135**.

Step 5.6b: CPU **131** of each Programmer **151-1**, **151-2**, . . . , and **151-n** informs controller **105** readiness for the next command in configurations using a two-way data link between a Programmer and controller **105**, e.g., configurations **700A** and **800A** of FIGS. **7** and **8**, respectively.

Step 5.7: Controller **105** sends the Program and Verify command to start the programming and verification process.

Step 5.8: CPU **131** of each Programmer **151-1, 151-2, . . . ,** and **151-n** programs and verifies its associated ISP system **100**.

Step 5.9: Controller **105** sends the Verify command to each Programmer **151-1, 151-2, . . . ,** and **151-n**. In configurations using two-way communication links, CPU **131** of each Programmer **151-1, 151-2, . . . , 151-n** returns to controller **105** status information regarding the programming operation.

5.10: Controller **105** displays on a monitor any failure in the programming of each ISP system **100** associated with each Programmer **151-1, 151-2, . . . ,** and **151-n**, where two-way communication links are used.

The operation of Programmer **151** (i.e., any of Programmers **151-1, 151-2, . . . , 151-n**) is summarized as follows:

Step 6.1: Programmer **151** waits in a standby mode until a command arrives from controller **105**.

Step 6.2: When Programmer **151** receives the Load programming data command from controller **105**, Programmer **151** reads programming data **109**, byte by byte, from parallel port **204** or serial port **115B** and stores programming data **109** into the associated RAM **135**.

Step 6.3: Having received programming data **109**, Programmer **151** signals controller **105** that step 6.2 is completed, where two-way communication between controller **105** and Programmer **151** is used.

Step 6.4: Programmer **151** then calculates a checksum for programming data **109** and compares the checksum thus calculated with the checksum appended at the end of programming data **109** to verify that the transmission was successful and that no data corruption has occurred in the transmission process.

Step 6.5: Programmer **151** reports the result of transmission to the controller **105**, where two-way communication between controller **105** and Programmer **151** is used.

Step 6.6: Programmer **151** waits for the next command from controller **105**.

Step 6.7: Programmer **151** receives the Program and Verify command, and transfers programming data **109**, byte from byte, from the associated RAM **136** into clocked memory element **137**.

Step 6.8: Clocked memory element **137** drives ispEN signals **99** low, thereby setting the associated ISP system **100** into a programming mode.

Step 6.9: Clocked memory element **137** drives SDI signal **93** and SCLK **95** signal to shift ISP instructions and programming data **109** into ISP devices **102**.

Step 6.10: Clocked memory element **137** drives MODE signal **97** and SCLK signal **95** to step ISP devices **102** in the associated ISP System **100** to complete the ISP programming cycles.

Step 6.11: Clocked memory element **137** drives SCLK signal **95** to shift data out from terminal **90** (SDO signal **91**) for the associated ISP system **100**.

Step 6.12: Clocked memory element **139** latches SDO signal **91**.

Step 6.13: The data in clocked memory element **139** is verified. If the programmed data fails to verify, Programmer **151** halts the programming process and reports an error, where the communication link between Programmer **151** and controller **105** is two-way.

Step 6.14: Steps 6.8–6.13 are repeated until the associated ISP system **100** is programmed.

Step 6.15: Where the communication link between Programmer **151** and controller **105** is bi-directional, Programmer **151** reports to controller **105** any failure in programming its associated ISP system **100**.

Step 6.16: Programmer **151** returns to Step 6.1.

The detailed description above is provided to illustrate specific embodiments of the present invention and is not intended to be limiting. Numerous variations and modifications within the scope of the invention are possible. The present invention is defined by the appended claims.

We claim:

1. A system for programming multiple programmable integrated circuits, comprising:

- a) an in-system programmable (ISP) system having a plurality of ISP devices;
- b) a programmer communicating with said ISP system, for programming said ISP devices;
- c) a controller communicating with said programmer, said controller transmitting control data and programming data to said programmer; and
- d) a communication link connecting said controller to said programmer, said communication link comprising a wireless data network.

2. The system of claim 1, wherein said ISP devices receive data input signals from said programmer and said programmer receives a data output signal from said ISP devices.

3. The system of claim 1, additionally comprising more than one of said ISP system, wherein said programmer is connected to all of said ISP systems for programming said ISP systems in sequence.

4. The system of claim 1, additionally comprising more than one of said programmer and said ISP system wherein each of said programmers is connected to one of said ISP systems for programming said ISP systems simultaneously.

5. The system of claim 1, wherein said programmer comprises a central processing unit.

6. The system of claim 5, wherein said programmer additionally comprises a writeable control store coupled to said central processing unit.

7. The system of claim 6, wherein said programmer additionally comprises a random access memory coupled to said central processing unit for allowing said programming data to be stored therewith and retrieved therefrom.

8. The system of claim 5, wherein said programmer additionally comprises a random access memory coupled to said central processing unit for allowing said programming data to be stored therewith and retrieved therefrom.

9. The system of claim 5, wherein said programmer additionally comprises an input clocked memory element coupled to said central processing unit for holding data input signals.

10. The system of claim 6, wherein said programmer additionally comprises an input clocked memory element coupled to said central processing unit for holding data input signals.

11. The system of claim 7, wherein said programmer additionally comprises an input clocked memory element coupled to said central processing unit for holding data input signals.

12. The system of claim 8, wherein said programmer additionally comprises an input clocked memory element coupled to said central processing unit for holding data input signals.

13. The system of claim 5, wherein said programmer additionally comprises an output clocked memory element coupled to said central processing unit for holding a data output signal.

14. The system of claim 11, wherein said programmer additionally comprises an output clocked memory element coupled to said central processing unit for holding a data output signal.

15. The system of claim 1, wherein said programmer additionally comprises a driver for transporting data input signals.

16. The system of claim 14, wherein said programmer additionally comprises a driver for transporting said data input signals.

17. The system of claim 1, wherein said controller comprises a host central processing unit.

18. The system of claim 1, additionally comprising a storage element from which said controller retrieves said programming data.

19. The system of claim 1, wherein said communication link additionally comprises a wired data network communicating with said wireless data network.

20. The system of claim 1, wherein said wireless data network comprises a transmitter for converting electrical pulses to radio wave signals and a corresponding receiver for converting said radio wave signals back to said electrical pulses.

21. The system of claim 1, wherein said wireless data network comprises a transmitter for converting electrical pulses to infra-red signals and a corresponding receiver for converting said infra-red signal back to said electrical pulses.

22. A system for programming multiple programmable integrated circuits, comprising:

- a) an in-system programmable (ISP) system having a plurality of ISP devices;
- b) programming means communicating with said ISP system for programming said ISP devices;
- c) controller means communicating with said programming means for transmitting control data and programming data to said programming means; and
- d) interface means for connecting said controller means to said programming means through a communication means, wherein said communication means is a wireless data network.

23. The system of claim 22, wherein said ISP devices receive data input signals from said programming means and said programming means receives a data output signal from said ISP devices.

24. The system of claim 22, additionally comprising more than one of said ISP system wherein said programming means programs said ISP systems in sequence.

25. The system of claim 22, additionally comprising more than one of said ISP system wherein said programming means comprises a plurality of programmers, each connected to one of said ISP systems, said programming means programs said ISP systems simultaneously.

26. The system of claim 22, wherein said programming means comprises a central processing unit.

27. The system of claim 26, wherein said programming means additionally comprises a writeable control store coupled to said central processing unit.

28. The system of claim 27, wherein said programming means additionally comprises a random access memory coupled to said central processing unit for allowing said programming data to be stored therewith and retrieved therefrom.

29. The system of claim 26, wherein said programming means additionally comprises a random access memory coupled to said central processing unit for allowing said programming data to be stored therewith and retrieved therefrom.

30. The system of claim 26, wherein said programming means additionally comprises an input clocked memory element coupled to said central processing unit for holding data input signals.

31. The system of claim 27, wherein said programming means additionally comprises an input clocked memory element coupled to said central processing unit for holding data input signals.

32. The system of claim 28, wherein said programming means additionally comprises an input clocked memory element coupled to said central processing unit for holding data input signals.

33. The system of claim 29, wherein said programming means additionally comprises an input clocked memory element coupled to said central processing unit for holding data input signals.

34. The system of claim 26, wherein said programming means additionally comprises an output clocked memory element coupled to said central processing unit for holding a data output signal.

35. The system of claim 32, wherein said programming means additionally comprises an output clocked memory element coupled to said central processing unit for holding a data output signal.

36. The system of claim 22, wherein said programming means additionally comprises a driver for transporting data input signals.

37. The system of claim 35, wherein said programming means additionally comprises a driver for transporting said data input signals.

38. The system of claim 22, wherein said controller means comprises a host central processing unit.

39. The system of claim 22, additionally comprising a storage means from which said controller means retrieves said programming data.

40. The system of claim 22, wherein said communication means additionally comprises a wired data network communicating with said wireless data network.

41. The system of claim 22, wherein said wireless data network comprises transmitting means for converting electrical pulses to radio wave signals and corresponding receiving means for converting said radio wave signals back to said electrical pulses.

42. The system of claim 22, wherein said wireless data network comprises transmitting means for converting electrical pulses to infra-red signals and corresponding receiving means for converting said infra-red signals back to said electrical pulses.

43. A method for programming multiple programmable integrated circuits, comprising the acts of:

- a) providing a controller;
- b) connecting said controller to a programmer through a communicating link, said communication link comprises a wireless data network;
- c) transmitting, through said communication link, programming data and control data from said controller to said programmer; and
- d) programming a plurality of in-system programmable (ISP) systems using said programmer.

44. The method of claim 43, wherein said communication link additionally comprises a wired data network communicating with said wireless data network.

45. The method of claim 43, wherein said wireless data network comprises a transmitter for covering electrical pulses to radio wave signals and a corresponding receiver for converting said radio wave signals back to said electrical pulses.



## 13

46. The method of claim 43, wherein said wireless data network comprises a transmitter for covering electrical pulses to infra-red signals and a corresponding receiver for converting said infra-red signals back to said electrical pulses.

47. The method of claim 43, wherein said programmer programs said ISP systems in sequence.

48. The method of claim 43, additionally comprising connecting said controller to a plurality of said programmers wherein each of said programmers is communicating with one of said ISP systems for programming said ISP systems simultaneously.

49. The method of claim 43, wherein said programmer comprises a central processing unit.

50. The method of claim 49, wherein said programmer additionally comprises a writeable control store coupled to said central processing unit.

51. The method of claim 50, wherein said programmer additionally comprises a random access memory coupled to said central processing unit for allowing said programming data to be stored therewith and retrieved therefrom.

52. The method of claim 49, wherein said programmer additionally comprises a random access memory coupled to said central processing unit for allowing said programming data to be stored therewith and retrieved therefrom.

53. The method of claim 49, wherein said programmer additionally comprises an input clocked memory element coupled to said central processing unit for holding data input signals.

54. The method of claim 50, wherein said programmer additionally comprises an input clocked memory element coupled to said central processing unit for holding data input signals.

55. The method of claim 51, wherein said programmer additionally comprises an input clocked memory element coupled to said central processing unit for holding data input signals.

56. The method of claim 52, wherein said programmer additionally comprises an input clocked memory element coupled to said central processing unit for holding data input signals.

57. The method of claim 49, wherein said programmer additionally comprises an output clocked memory element coupled to said central processing unit for holding a data output signal.

58. The method of claim 55, wherein said programmer additionally comprises an output clocked memory element coupled to said central processing unit for holding a data output signal.

## 14

59. The method of claim 43, wherein said programmer additionally comprises a driver for transporting data input signals.

60. The method of claim 58, wherein said programmer additionally comprises a driver for transporting said data input signals.

61. The method of claim 43, additionally comprising retrieving, prior to act (c), said programming data by said controller from a storage element.

62. The method of claim 43, additionally comprising indicating, subsequent to act (d), programming results of said ISP systems.

63. A method for programming multiple programmable integrated circuits, comprising the acts of:

- a) providing a controller;
- b) transmitting programming data and control data from said controller to a programmer; and
- c) programming a plurality of in-system programmable (ISP) systems using said programmer;

wherein said programming act comprises providing data input signals to said ISP systems and receiving data output signals from said ISP systems, said ISP system containing a plurality of daisy-chained ISP devices.

64. A system for programming multiple programmable integrated circuits, comprising:

- (a) an in-system programmable (ISP) system having an ISP device;
- (b) a programmer communicating with said ISP system to program said ISP device, said programmer having a central processing unit, a writeable control store, a random access memory, an input clocked memory element, and an output clocked memory element; and
- (c) a controller transmitting data to said programmer through a communication link.

65. The system of claim 64, wherein said programmer additionally comprises a driver.

66. The system of claim 64, wherein said communication link comprises a wired data network.

67. The system of claim 64, wherein said communication link comprises a wireless data network.

68. The system of claim 67, wherein said wireless data network is operated by a transmission of radio wave signals.

69. The system of claim 67, wherein said wireless data network is operated by a transmission of infra-red signals.

\* \* \* \* \*